



PRODUCT MANUAL



KIT CLASSICS HO SCALE 40' TRANSITION ERA REEFER

Relive the Golden Years of model railroading with **Kit Classics™** freight car kits. When you assemble these simple kits, you'll rediscover fond memories of power packs, sectional track, shake-the-box kits, and dreams of creating your own model railroad empire. Kit Classics freight cars are perfect for sharing this timeless tradition with the next generation of model railroaders. All that's needed for assembly is a Phillips screwdriver, glue, and a few minutes to build.

Railroads created refrigerator cars in the late 1800s to transport perishable products such as meat, fruits, and vegetables. The

cars were built with insulated sides and various cooling methods were used, with the most popular being ice. Ice was loaded into bunkers on the roof of the car, and cool air circulated over the ice to keep the contents cool. Initially, the cars were made entirely of wood, but by the early 1900s, wood bodies were combined with steel ends and roofs. In 1936, all steel cars became the norm. In the 1950s, mechanical refrigeration was developed, which replaced ice reefers. However, steel ice reefers could still be seen until the early 1970s.

- **Multiple road numbers**
- **Finely cast stirrup steps; end ladders; grab irons; underbody and brake system**
- **Easy-to-assemble with small Phillips screwdriver and glue**
- **Separately applied handbrake wheel**
- **One piece detailed molded trucks**
- **33" Machined metal wheels**
- **Accurately profiled .110" wide wheel tread**

- **Plastic semi-scale Type E knuckle couplers, Kadee compatible**
- **Body mounted coupler box will accept Kadee whisker couplers**
- **Weighted to Industry standards**
- **Operates on Code 70, 83 and 100 rail**
- **Packaging safely stores model when assembled**
- **Minimum radius 18"**



PRODUCT SUPPORT

U.S. 844-9TRAINS; 844-987-2467 Ext. 2
International 423-299-3689
Support@ScaleTrains.com



ScaleTrains

4901 Old Tasso Rd NE,
Cleveland, TN 37312 USA



www.ScaleTrains.com

SIGNUP FOR OUR WEEKLY NEWSLETTER
www.ScaleTrains.com/newsletter

WARRANTY POLICY

ScaleTrains.com, Inc. (ScaleTrains) warrants products purchased from our website to be free from defects in material and workmanship for a period of two (2) years from the date of purchase. Products purchased directly from ScaleTrains are automatically registered and a receipt is not required for proof of purchase.

ScaleTrains warrants products purchased from an authorized Select Retailer to be free from defects in material and workmanship for a period of one (1) year from the date of purchase. The warranty period can be extended to two (2) years by registering the product within 30 days of purchase on our website at www.ScaleTrains.com/warranty. Be sure to retain the receipt as proof of purchase as it may be required in the event your model requires warranty service by our Service Center.

If the product fails during the limited warranty period, carefully pack the model in the original packaging. Be sure to include an explanation of the issue(s) along with your name, address, phone and email. If the product(s) were purchased from a Select Retailer, include a legible copy of the sales receipt.

Ship item(s) for repair to our Service Center at...

ScaleTrains Service Center
4901 Old Tasso Road NE
Cleveland, TN 37312

We recommend using a trackable shipping service. Shipping damage incurred on the way to our service center and costs associated with shipping are not covered under warranty.

Damages due to improperly storing, handling, or packaging are not covered under warranty.

If ScaleTrains.com deems the product to be defective, we will either (1) repair (2) replace the item, or (3) offer a store credit redeemable at ScaleTrains.com toward a future purchase. This determination is at the sole discretion of ScaleTrains.

ScaleTrains has the final decision on all warranty matters. The warranty policy is subject to change without notice.

ScaleTrains • 4901 Old Tasso Rd NE, Cleveland, TN 37312 • www.ScaleTrains.com

Toll-Free 844-9TRAINS • International 423-299-3689

WARNING: This product may contain a chemical known to the State of California to cause cancer or birth defects or other reproductive harm.
© 2023 ScaleTrains.com, Inc., ScaleTrains, Rivet Counter and respective logos and slogans are trademarks of ScaleTrains.com, Inc.



SXT81885

As with any model kit, before you start the assembly, take few moments to familiarize yourself with the various parts of the kit. Assembly is easy and straight forward. You will need the following tools.

1. Sharp hobby knife
2. Small Phillips screwdriver
3. Hobby glue for bonding plastic parts
4. Small tweezers

STEP 1 Secure the weight to the floor with supplied screws

STEP 2 Turning the floor over, place the brake rigging assembly over the corresponding holes. Working from the center of the car, secure the air tanks, triple valve and brake levers, working your way towards the ends of the brake rods.

STEP 3 Noting the orientation of the coupler centering springs, install one spring in each coupler box. Place the coupler in the box making sure that the coupler shank is centered between the two fingers of the centering spring. Attach the coupler box lid with the screws and check for proper coupler centering operation.

STEP 4 Install the trucks with the supplied screws.

STEP 5 Install the floor into the body, making sure the brake cylinder points toward the brake end of the car. You may need to spread the body slightly to snap the floor in place.

STEP 6 Install the roofwalk onto the body. The post along the roof will snap into place. Take special care to insert the roofwalk supports at the ends of the car into the corresponding holes

STEP 7 Install the brake wheel

Your reefer is now ready to start generating revenue for your railroad. Enjoy.

KIT CLASSICS HO SCALE 40' TRANSITION ERA REEFER PARTS LIST

- SXT81885 Instruction Sheet
- SXT81886 Body
- SXT81887 Roofwalk
- SXT81888 Brakewheel
- SXT81889 Floor
- SXT81890 Brake System Detail
- SXT81891 Coupler Box Cover
- SXT81892 Weight
- SXT81883 Screw, Ring Head, Self-Tapping (For Plastic) 2.0MM X 4.0MM
- SXT81884 Truck Friction Bearing
- SXT81865 Screw, Flat Head, Self-Tapping (For Plastic) 2.0 X 4.0MM
- SXT81866 Screw, Ring Head, Self-Tapping (For Plastic) 1.6MM X 3.5MM
- SXT80168 Type E coupler - Plastic 2 Pr.
- SXT80169 Type E coupler - Plastic 6 Pr.
- SXT80205 Coupler Centering Spring
- SXT80206 Coupler Knuckle Spring

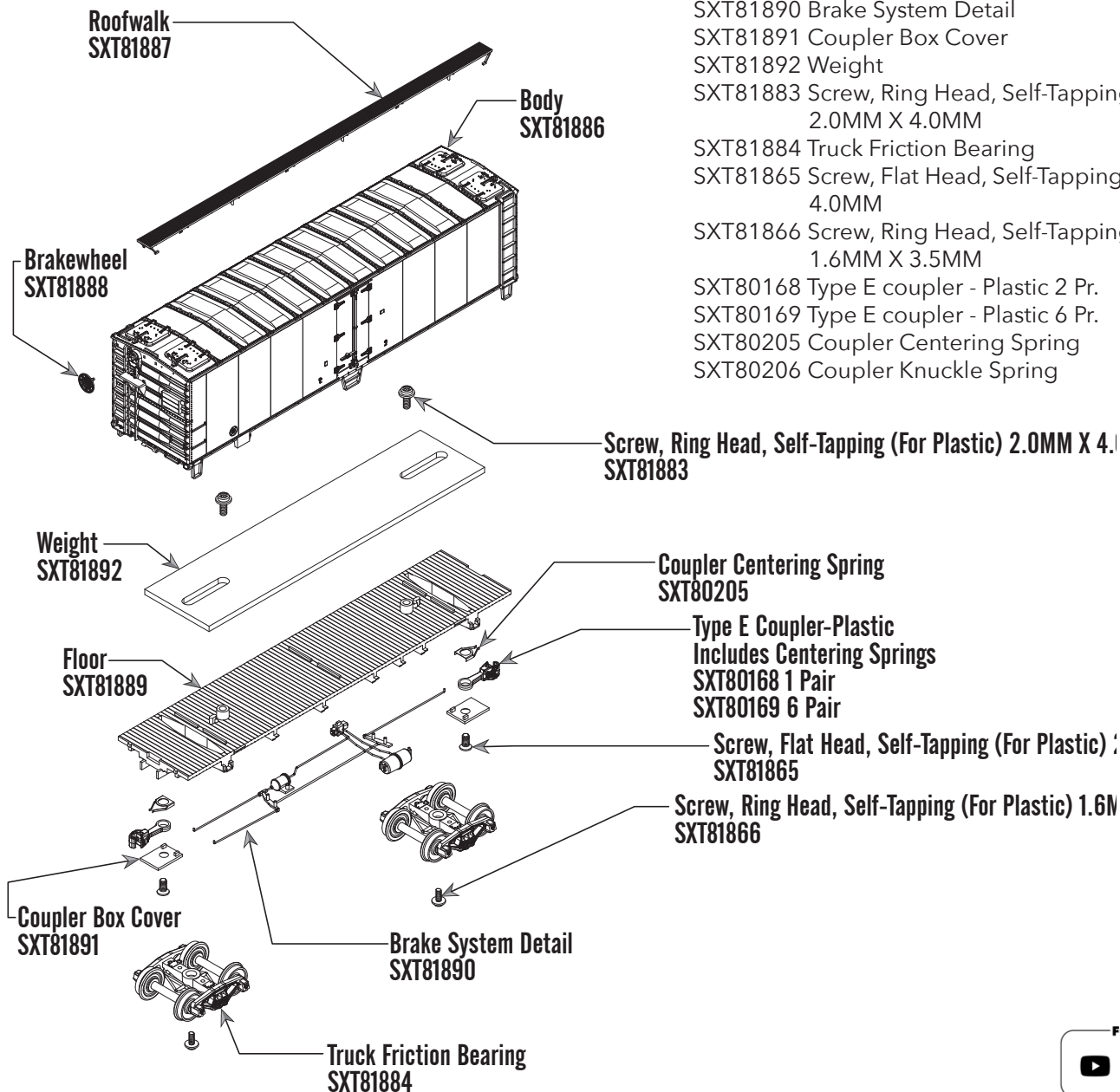

FOLLOW SCALETRAINS

